

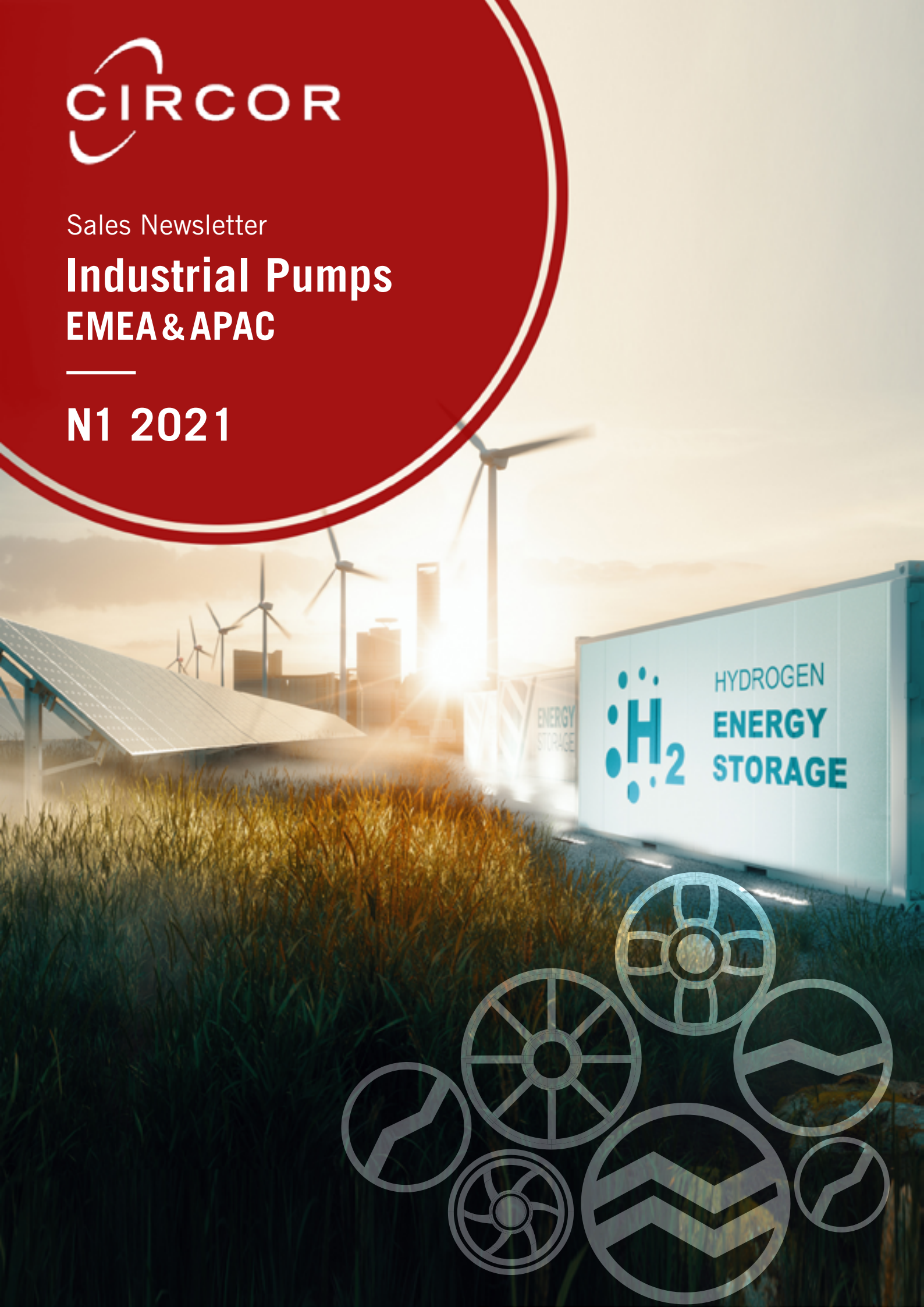

Sales Newsletter

Industrial Pumps EMEA & APAC

N1 2021





Dear all,

As the world continues to tackle the challenges of the pandemic, there is now certainly a lot more bright light on the horizon. While we can't let down our guard, COVID-19 has ceased to be our all absorbing center of attention. To the contrary, in most countries our lives are gravitating towards a 'new normal', in which we can go about our daily lives and capitalize on the significant business opportunities that have been opening up again. As a matter of fact, during the first and second quarter of this year and thanks to your support and commitment, we have received orders at a level not seen in recent years. While this was partially driven by a backlog of unspent CAPEX, it is clearly a reflection of a much improved business sentiment.



As we spend again more time looking at the future, let me draw your attention to a few contributions in this edition. As the world is in need of more environmentally sustainable solutions, we are very excited to share with you an update on one potentially important technology to reduce the carbon footprint of the global mobility sector, referred to as Power-to-Liquid (P2L). Please take a look at the various opportunities, which are currently being created in this space and where we are already active. If you come across such an opportunity in your area or region, please don't hesitate to contact us. We have full confidence in our ability to support you accordingly. Next, you will find an article on recent successes with the Hengli group in the chemical industry in China. While we have been serving this industry since a long time, we have increased our efforts to more effectively serve this market around the globe. Thirdly, I would like to point out another significant development in a market, we don't talk about all that often: Navy. As this market is similar to the Commercial Marine market in some ways, we are principally very well positioned to serve our customers there. We are now making investments in Tours (France) in order to establish this site as a center of excellence for Navy to better serve customers not only in France but everywhere outside of the US. This has already started to yield results, as reflected in our significant increase in bookings in 2021.

As you can see, there are a lot of reasons for us to be excited about the future. So, let's continue to intensify our collaboration in these turbulent times. I am convinced that the best still lies ahead of us!

Best regards

Daniel Stirpe
VP/GM Industrial Pumps EMEA & APAC

CIRCOR Confidential & Proprietary



SECTION

1

SECTION

3

SECTION

5

SECTION

2

SECTION

4

INSIDE CIRCOR

Mission, Vision, Purpose

CUSTOMER FOCUS

Success Story Power to Liquid

Success Story China Chemical Industry

Success Story Magnetic coupled pumps for the Plastic Industry

Success Story Australian Navy

Customer Focus New Oil Test Bench in CIRCOR France

SALES CHANNEL

New Partners in EMEA: Ireland+UK

New Partners in Malaysia

New Partners in Vietnam

Channel Partner Meeting

Introducing our Sales Channel Partner Managers

Customer Service Contact Data

PRODUCTS & SOLUTIONS

Allweiler Dosing Pump AEB-DE

New CIRCORSmart App

MARKETING UPDATES

Allweiler Service Portal

Training 2021

INSIDE CIRCOR

EXCELLENCE IN FLOW CONTROL

CIRCOR manufactures flow and motion control products for the world's most severe-service and mission-critical applications—from valves to instrumentation, actuation to pumps, motors to regulators.

Our Mission

Delivering Smart, Reliable Flow Control Solutions for Mission Critical Applications



When failure is not an option

Our Vision

To be the Leading Global Flow Control Technology Company



Creating long term value in every aspect of our business.

CIRCOR Confidential & Proprietary



Our Purpose

Keeping society safe, productive and moving



Many roles. One purpose.

A foundation for success.

- Our singular purpose makes us more effective at achieving our mission.
- Knowing why we do what we do allows us to become better at doing what we do.
- Our alignment on goals, creates a culture of reliability and consistency that delivers results.

Committed to the future



CIRCOR Confidential & Proprietary

Success Story

POWER TO LIQUID – NEW TECHNOLOGY FOR A SUSTAINABLE FUTURE

Ability to deliver complete pump packages on-time with the highest level of quality

Environmentally sustainable technologies are the future of the energy market. One potentially important technology to reduce the carbon footprint of the global mobility sector is called Power-to-Liquid (P2L).

The P2L process converts renewable energy, water and carbon dioxide to synthetic fuel, which can be used to power hard to electrify transport modes like aircrafts, vessels or trucks with zero emissions. Additionally, the produced hydrocarbon chains can be used as a renewable base material source for the Chemical, Cosmetics or Food Industry. While current operating P2L plants are mostly in a pilot phase, Allweiler was already able to create pump references in various process steps. Following the P2L process step-by-step:

1. Renewable Electricity

Renewable electricity obtained from renewable sources like wind, solar, water or geothermal.

Input: Renewable energy source

Output: Electricity

Circor Pump Opportunities: Various, for example in hydro power plants.

2. Electrolysis

Electrolysis splits water into hydrogen and oxygen. Oxygen dissipates into the surrounding air.

Input: Demineralized Water, Electricity

Output: Hydrogen

Circor Pump Opportunities: Demineralized Water Feed Pumps (Centrifugal CNH-B, CMA, CNH-M), Cooling Water Pumps (Centrifugal NT, CNH-B)

3. Conversion

The conversion is a two-step-process. In the first step, Carbon Dioxide and Hydrogen are converted to Synthetic Gas in the Reverse-Water-Gas-Shift reactor. For that, Carbon Dioxide is captured from a renewable source or directly from the air. In the second step, SynGas is used by the

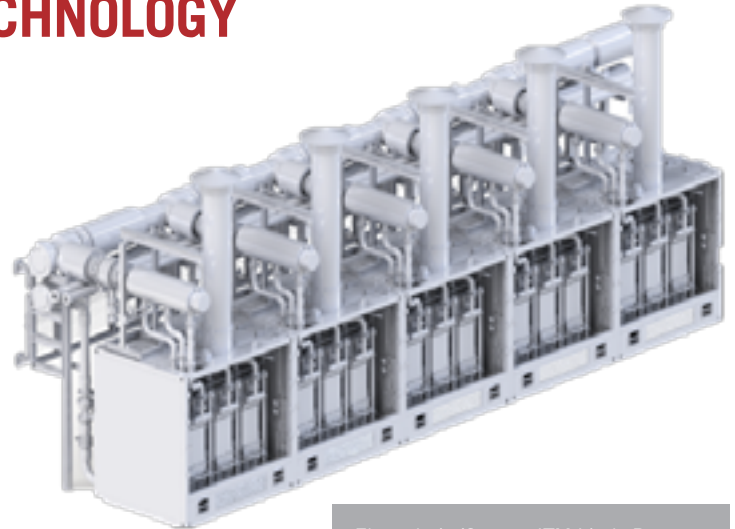

Electrolysis (Source: ITM Linde Power, HGasXMW PEM Modules)

Fischer-Tropsch reactor to produce hydrocarbon chains. Process heat may be used for residential or industrial areas.

Input: Hydrogen, Carbon Dioxide

Output: Synthetic Crude Oil (Hydrocarbon Chains in the form of oil and wax), Heat

Circor Pump Opportunities: Booster, Cooling, Circulation Pumps in the FT-Process (Centrifugal CMA, CNH-M, CNH-B, Side Channel), Loading pumps for FT-Wax and Oil (CMA, Side Channel, 3-Screw)

4. Refining the final product

For mobility purposes, the Fischer-Tropsch product (synthetic crude oil) can be refined to fuel in a common refinery. The resulting Syn-Fuel is compatible to existing infrastructure and engine technologies and replaces fossil fuel.

Input: Synthetic Crude Oil (Hydrocarbon Chains in the form of oil and wax)

Output: Synthetic Fuel / Syn-Fuel / E-Fuel

Circor Pump Opportunities: Same as current portfolio for Petrochemical Industry

If you have any project or customer related to the P2L process, please contact your Circor representative so that we can jointly discuss how we can support the customer with our solution.



WHOLE PROCESS

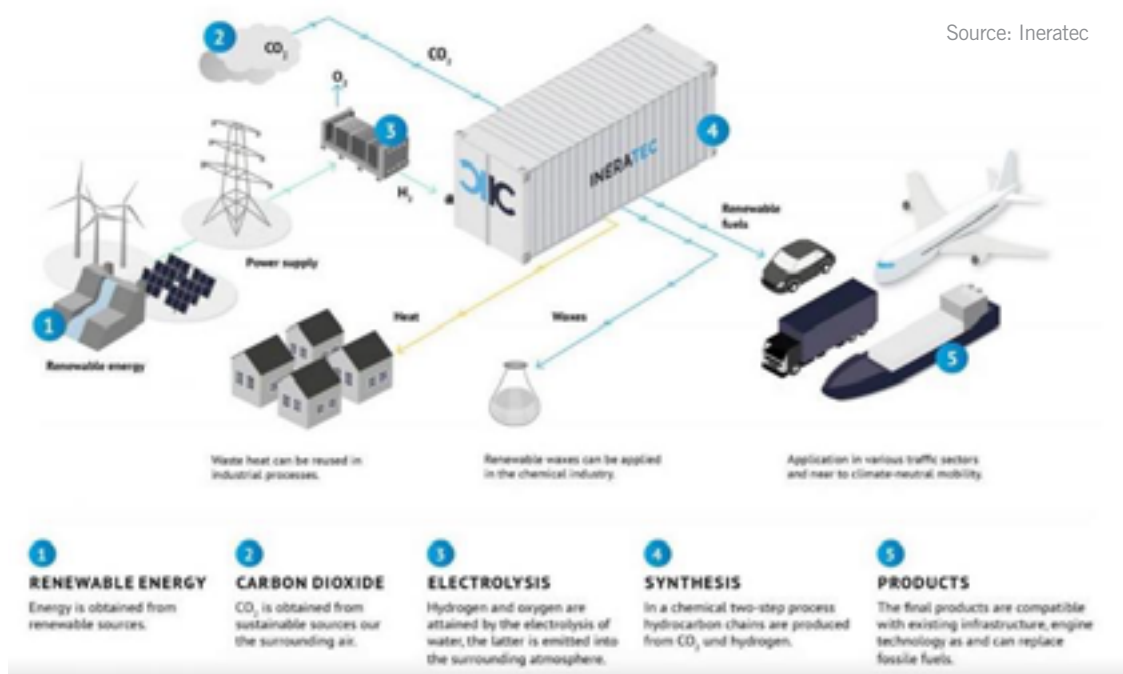

WHOLE PROCESS

POWER-TO-X PATHWAYS

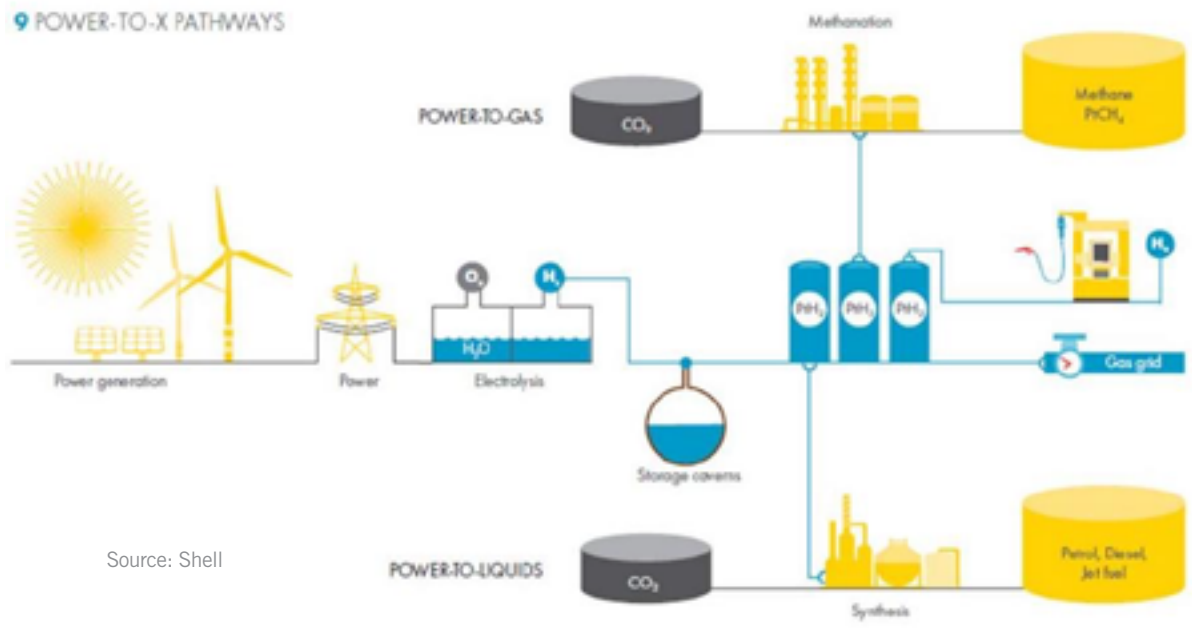

Source: Shell



Success Story

CHINA CHEMICAL INDUSTRY

ALLWEILER wins project with 435 pumps for the world's largest PBS plant.



Hengli Production at Yingkou Kanghui Petrochemical Co.,Ltd. Plant

Overview

With its 120.000 employees, the Hengli Group is world-wide a leading company in the segments of oil refining, petrochemical, advanced polyester materials and textiles. The group owns one of the largest functional fiber production bases and holds an award as "The Environment-friendly Enterprise of Chemical Fiber Industry China". Currently, Hengli Group and its company Yingkou Kanghui Petrochemical Co.,Ltd. are building a new site for the production of 800,000 tons of polyester, that includes a PBS production, a biodegradable polymer known as green plastic. This is the largest PBS project in the world. Within this project, more than 800 pumps are requested for process applications, heat transfer and temperature control of the equipment within the plant.

The Challenge

For this project ALLWEILER was approached by our authorized channel partner Nanjing Euro Pump to quote for the thermal oil applications with its high technical and qualitative standards. Since safety is one of Hengli's top priorities and the technical requirements are therefore high, double mechanical seal pumps were requested. Although, ALLWEILER already has many successful references from previous Hengli projects, the challenge was to submit a quotation within the shortest possible time while meeting the technical specification, the delivery time and the customer's price level to be prepared for contract negotiation. This was the prerequisite for bearing the great competition from KSB and Ebara.

The Solution

Through the excellent cooperation of the EMEA ALLWEILER Radolfzell and the CIRCOR Shanghai team, the customer's requirements were identified, and the appropriate measures were quickly taken to make positive steps towards placing the order. As double-acting mechanical seals were specified, ALLWEILER quoted its chemical pump type CNH-B with special execution instead of standard thermal oil pumps and type CWH is used for large flow rates. Thanks to the great cooperation with the Supply Chain team, the best possible delivery times and capacities were clarified at an early stage, and the customer's price level could be met through early supplier negotiations which ultimately set us apart from the competition.



CIRCOR Confidential & Proprietary



”

We think, It is a great win, not just because of high specs from customer, changes and clarifications during quotation, or heavy workload, but because of the great team work Among Allweiler, Weihai and also commercial team, which well demonstrated our quick response, professional and responsibility to finally win the trust of customer.



Sarah Werner
Technical Sales

The Result

ALLWEILER is supplying 435 chemical pumps worth several million dollars in Q3. By winning this project, which is the biggest PBS investment in the world, indicates ALLWEILER now is the leader for this application in the segment and could double its normal annual volume of CNH-B pumps with potential for aftermarket and future programs.

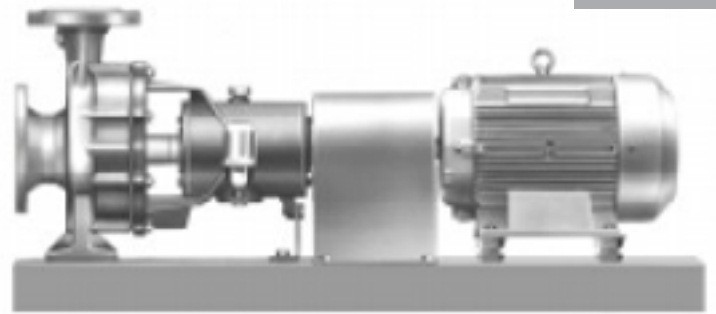

CNH-B Pump

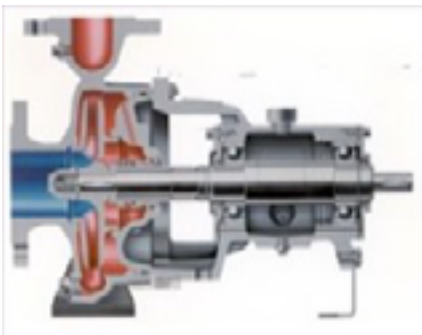

CNH-B Pump

”

We think, It is a great win, not just because of high specs from customer, changes and clarifications during quotation, or heavy workload, but because of the great team work Among Allweiler, Weihai and also commercial team, which well demonstrated our quick response, professional and responsibility to finally win the trust of customer.”



Kevin Shen
China Sales Manager
Industrial Pumps



Tracy Tracy Zhang
Senior application engineer

CIRCOR Confidential & Proprietary



Success Story

MAGNETIC COUPLED PUMPS FOR THE PLASTIC INDUSTRY



Overview

Elantas Europe is a worldwide leading manufacturer of insulating and protective materials with focus on the global electrical and electronics industry.

Specifically, the company offers a comprehensive portfolio of wire enamels, impregnating resins and varnishes, casting and potting resins, flexible electrical insulation materials, materials for electronic protection, specialty industrial coatings, products for printed electronics as well as a wide range of tooling and composite materials.

The Challenge

The site located in Quattordio (Italy) is mainly specialized in varnishes (impregnating and finishing) and wire enamels.

After a very long and positive experience with NTT pumps for heat transfer application, a new requirement has been introduced: improve the plant safety level and minimize, at the same time, the impact on the environment. In other words, to avoid any potential leakage.

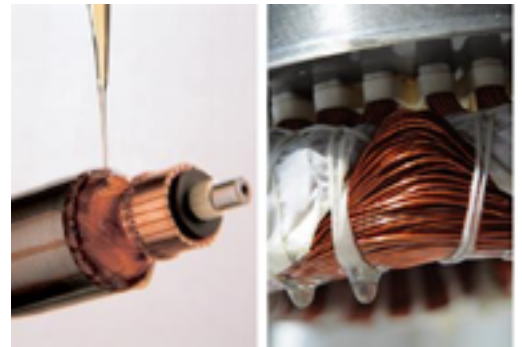



Allweiler NTT

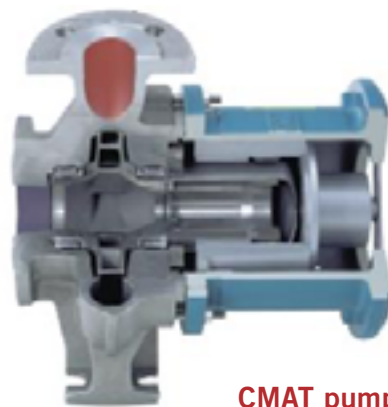

CMAT pump



1.3 Previous configuration



1.4 New configuration

The Solution

Included in its wide portfolio, Allweiler offers centrifugal pumps a series that can perfectly satisfy this need: ALLMAG series.

The ALLMAG series is equipped to meet the challenge thanks to the magnetic drive feature, that makes the pump hermetically sealed and, as a result, leak and emission-free. Considering the medium-low performance required by the application, the block design (called CMAT) has been proposed. In this way, the customer can have an additional advantage: a very compact unit compared to the previous NTT pumps. The scope of supply consists of 6 CMAT complete units and 3 additional units as spare pumps.

The picture 1.3 shows the previous configuration, consisting of three NTT pumps working in parallel. The two side units were supplying two boilers, while the central unit was in stand-by. The service is continuous (24/7)

The picture 1.4 shows the new configuration, where the new CMAT units have successfully replaced the old NTT pumps.

We are very proud of this success story and we wish our customer the best possible experience with the new pumps. In addition, we expect to meet again this requirement in the near future. Based on this experience, we are sure that we will satisfy other customers.

CIRCOR Confidential & Proprietary



Success Story

AUSTRALIAN NAVY

CIRCOR Defense EMEA team was in 2020 awarded a \$1 M contract to support the Collins Class submarine life extension by the Commonwealth of Australia and Adelaide Shipyard Corporation.

Securing this project speaks to the success of CIRCOR's longtime partnership with Australian Pump Industries, a major player in Australia. Over the last 20 years, this company has played a major role in supporting Australia's Defence industry, particularly in key mission-critical assets on Navy platforms.

The recent investment by the Commonwealth in 9 frigates and 12 new submarines is a harbinger of much more involvement by CIRCOR in the area, as it comes with a subsequent requirement for ongoing industrial engagement. CIRCOR and Australian Pump are ready to meet that challenge!



It is in the continuity of the paper made in 2020 that led our Australian Partner to be our Defense customer n°1 of the year.

We intend this fruitful partnership to continue in regards to the significant forthcoming Defense projects Australia listed below.

AUSTRALIAN FOCUS + LOCAL PARTNERSHIP "PROJECTS OF THE CENTURY"

S1000 Submarine

- 12 SSK Submarines "Barracuda Shortfin" designed by Naval Group - France
- Built by Naval Group & ASC
- First Delivery Q4 2024, 3 year cadence

S5000 Combatant

- 8 T26 Frigates designed by BAE Systems
- Built by ASC
- First Delivery Q1 2023, 1.5 year cadence

S1180 Patrol Vessel

- 12 OPV based on Lurssen Design
- Built by ASC & CIVEC shipyards
- First Delivery Q1 2019, 1 per year

Collins Class Submarine 20 year life Extension

- Aftermarket support and possible retro fit
- ASC lead yard





Customer Focus

NEW OIL TEST BENCH IN CIRCOR FRANCE (TOURS)

To meet the French Navy's needs, CIRCOR France (TOURS) created and developed a specific oil test bench. The Navy's specifications are strict for strong acoustics improvements for submarines applications. That is why, for a year and a half, CIRCOR France's technical team worked on a new test structure capable of measuring our pumps performances for different operating conditions. The new test bench they have created can modify physical parameters such as fluid aeration, viscosity, vacuum at suction piping, temperature, flow rate, and rotation speed.

Last summer, our production workers assembled the test bench to begin testing of our product for the end of August. All parts are made of stainless steel, and there are fluid visualization parts at the suction and discharge pipes. Moreover, the tested pumps are on a seismic platform decoupled from the ground to precisely measure the equipment's vibration. After a vigorous testing and handling period, a trial campaign looking into quantifying acoustic trends of a prototype pump built for future French submarines was successfully carried out.

The technical team is currently working on a new water test bench scheduled for summer 2021. These projects are in line with CIRCOR France's vision to develop its testing capacity and technological means to answer our customers' needs worldwide.



This project will improve our testing facilities in order to increase possibilities, quality & efficiency of measurement."

About Geoffroy LEBLANC

Work As Test engineer by CIRCOR pumps - IMO and ALLWEILER - in Tours- France for the Navy market.

What do you like more to work in CIRCOR

Team work for providing innovative, technical and quality solutions to answer to requirements of our customers is what I like about my work at CIRCOR.

Geoffroy Leblanc

SALES CHANNEL FOCUS

NEW PARTNERS IN EMEA: IRELAND & UK

CIRCOR is proud to announce that we have been able to complete the United Kingdom and Ireland with a total four channel partners in 2020 and 2021. In the UK & Ireland we have chosen a regional approach ensuring close proximity to our customer base. With the diligent effort of our Sales Manager Sunith Dsouza we have been able to qualify two partners in 2020 with Ferrier Pumps serving Scotland and Durham Pumps serving Northern England. In 2021 the additional two

territories have been filled with Hayley Group serving England & Wales as well as Henry R Ayton serving Ireland & Northern Ireland. We are very excited to have four strong partners in our channel network. Our partners in the UK & Ireland have expertise in industrial sales plus strong service capabilities. With those to features we are very confident to deliver excellent service to our customer base in the UK & Ireland.



FERRIER PUMPS LIMITED
Edinburgh • Glasgow • Aberdeen

- Serving Scotland



- Serving Ireland & Northern Ireland



- Serving Northern England



Member of DEXIS Europe

- Serving England – Midlands, South & East plus Wales

CIRCOR Confidential & Proprietary



NEW PARTNERS IN MALAYSIA



Encord Sdn Bhd is a Malaysia based company established in September 1997 with the objective to specialize in industrial valves and other associated engineering equipment. With a proven track record and reputation for exceptional service, Encord has today established itself as a premier Valve Supplier and Valves Distributor in Malaysia, Singapore and China for a broad spectrum of industries which may include Palm Oil Refinery, Oleochemical, Chemical, Cleanroom, Food and Beverage, Water Works and General Industries.

Leveraging on the existing portfolio from the industrial valves business, Encord aims to create more value-added service by introducing Circor pumps to our existing customers. Earlier success in securing inquiries of Allweiler centrifugal pump for local thermal heating system provider and Allweiler peristaltic pumps for new disinfection systems in Johor River Waterworks of PUB gave a promising confidence for Encord team to deliver value to our existing customers as well as Circor as a principal. More success stories are to be written in the coming years!

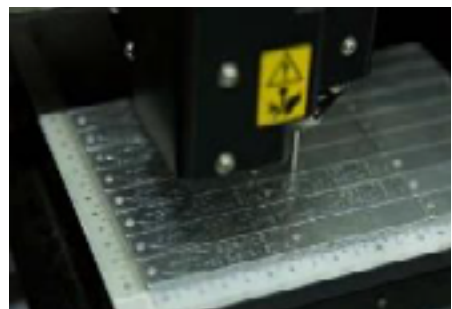

CIRCOR Confidential & Proprietary



NEW PARTNERS IN VIETNAM

Initially Exion Asia Vietnam Representative Office was set up in 3Q of 2012 and later Exion Vietnam Co., Ltd was set up and in operation since 1st March 2014.

The long-term plan is to become a flow control solutions provider under Pon Asia group, Exion Vietnam are the sister company to Exion Singapore and will focus on Zenith Pumps in the following markets, Chemical, Energy, Food & Beverage, Home & Personal Care, Manufacturing & Water industries.



CHANNEL PARTNER MEETING

Channel Partner Meeting EMEA GI – Q2 2021 - Industrial Pumps EMEA & APAC

Engaging with our Channel Partner Network the EMEA General Industry distribution management team has hosted a Channel Partner Meeting in April. The 57 active participants joined the virtual meeting covering the full regional factettes of the EMEA territory – from Finland to South Africa as well as Spain to Russia. In this lively and interactive event two of our distributors have presented their key to success and growth. In one case by serving the customer with technical support when facing challenges in the site operation, creating value for the end-user. The second success story focused on an excellent sales operation with updated online presence and CRM implementation to achieve growth despite a challenging market 2020. Joint team effort with the CIRCOR AM & FM sales teams received very positive feedback for key initiatives such as the implementation of smart tags (QR-code) on our pumps.

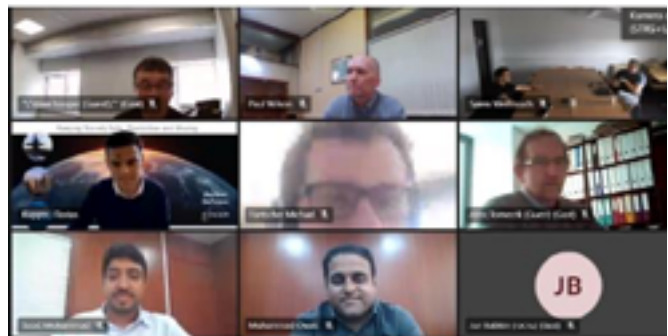
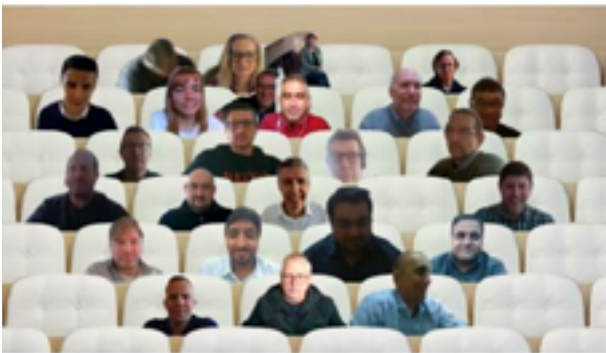

CIRCOR Confidential & Proprietary



INTRODUCING OUR SALES CHANNEL PARTNER MANAGERS



FLORIAN KUPPER

Where are you located?

I am based in Germany. I live and work close to Nuremberg

When did you first join the company?

I joined Allweiler and CIRCOR in 2017. My initial role was Field Sales in Bavaria, Germany

For which territories and markets are you responsible as Channel Sales Manager?

I have the pleasure of working with our Distributors in Eastern Europe direct while I support the Rest of Europe Sales team in Channel management

What do you love about your job?

The parts of my job I enjoy the most is related to working with people. Working with customers, partners and the team is something that I appreciate very much.

How do we win in front of our customers against our competition?

Listening actively and consciously in conversations with customers is something that I consider a strength of mine. Understanding the demand well helps us make the matching proposal.

How do you manage to stay in contact with your channel partners during the Covid-19 pandemic?

MS Team meetings and telephone conversations have been important for me in 2020 as well as the first months in 2021. A highlight for me was the EMEA GI Channel Partner Meeting in April.

What else would you would like to share about you?

In recent years I have regained interest in reading non-fiction. Viktor Frankl's "Man's Search For Meaning" was the book that left a lasting impression on me.



ILARI LEHTINEN

Where are you located?

In Vantaa, Helsinki area, Finland.

When did you first join the company?

I started 1st of January 2020.

For which territories and markets are you responsible as Channel Sales Manager?

My territory are the Nordic countries. As Industry Sales manager I work with Key OEM accounts and distribution partners.

What do you love about your job?

Meeting customers and to increase sales together.

How do we win in front of our customers against our competition?

I like to focus on the quality of our product. We are known as a superior brand in pump world. High quality products with long heritage.

How do you manage to stay in contact with your channel partners during the Covid-19 pandemic?

Daily emails, phone discussions and Teams meetings. Waiting to meet all customers face-to-face.

What else would you would like to share about you?

I have always bag of frisbee golf disks in the car trunk.



DANIEL LANGEREIS

Where are you located?

In Utrecht, the Netherlands.

When did you first join the company?

In March 2021.

For which territories and markets are you responsible as Channel Sales Manager?

I serve the BeNeLux region. My markets are mostly larger End-User and OEM accounts in General Industry for Mission Critical Pumps and Parts as well as our Channel Partners in Belgium and the Netherlands.

What do you love about your job?

The broad spectrum of customers I deal with on a day to day basis from chemical plants to water treatment and waste management companies. There are an astonishing amount of markets and customers I deal with, each unique in their own way.

How do we win in front of our customers against our competition?

I remind our customer on the length of time our trouble-free equipment has been operating in their facility, and their choice for our equipment will reflect positive on them in cost cutting and maintenance free operations.

How do you manage to stay in contact with your channel partners during the Covid-19 pandemic?

Having joined CIRCOR in March 2021 most introductory conversations were virtual and I tried to meet face to face as soon as possible.

What else would you would like to share about you?

90% of success is just showing up prepared.



SUNITH DSOUZA

Where are you located?

Harrow in Greater London. Close to the world renowned Harrow School which produced 7 UK Prime Ministers and numerous celebrities.

When did you first join the company?

April 2018.

For which territories and markets are you responsible as Channel Sales Manager?

I am responsible for general industry sales in the United Kingdom & Ireland. Over the recent years I have been able to qualify channel partners for the complete territory.

What do you love about your job?

Interacting on a daily basis with the customers, channel partners and colleagues. Discussing opportunities and also the banter.

How do we win in front of our customers against our competition?

Superior product quality and a wide range of products for a wide range of applications.

How do you manage to stay in contact with your channel partners during the Covid-19 pandemic?

Regular communication via phone, emails or MS Teams. Looking forward to meeting with them with the lifting of the restrictions now.

What else would you would like to share about you?

John Grisham fan, love international cricket and rugby, solving crosswords and quizzes.



CUSTOMER SERVICE CONTACT DATA

CONTACTS FOR SUPPORT IN YOUR SALES WORK

APPLICATION ENGINEERING

- Centrifugal & Propeller Pumps ae-emea-gp@circor.com
- 3-Screw Pumps ae-emea-gs@circor.com
- PC -, Hose Pumps and Macerators ae-emea-ge@circor.com

ORDER ENTRY PUMPS

- Centrifugal & Screw and Propeller Pumps orders-emea-gr@circor.com
- PC -, Hose Pumps and Macerators orders-emea-ge@circor.com

AFTERMARKET INQUIRIES

- Centrifugal, 3-Screw and Propeller Pumps cc-emea-gr@circor.com
- PC -, Hose Pumps and Macerators cc-emea-ge@circor.com

AFTERMARKET ORDERS

- Centrifugal, 3-Screw and Propeller Pumps orders-mam-allweiler-gr@circor.com
- PC -, Hose Pumps and Macerators cc-emea-ge@circor.com

SERVICE ENGINEERING

- Centrifugal, 3-Screw and Propeller Pumps service-emea-gr@circor.com
- PC -, Hose Pumps and Macerators service-emea-ge@circor.com

PRODUCTS & SOLUTIONS

ALLWEILER PROGRESSING CAVITY PUMP AEB-DE DOSING PUMP SERIES

FOUR PUMP SIZES ONE INSTALLATION FOOTPRINT

A NEW ALLWEILER TRADITION FOR FLEXIBLE INSTALLATION

Metering and dosing of high viscosity and particulate-filled fluids requires a progressing cavity pump that can achieve high efficiency and failure-free operation.

The next-generation ALLWEILER AEB-DE dosing pump series have combined proven and long lasting features from our trusted industrial pump range with optimized rotor and stator geometries for the utmost in accurate metering.

But the added value this new series offers sets a new bar for flexible installation.



THREADED



FLANGED



OPTIONAL BASEPLATE



FOUR PUMP SIZES. ONE INSTALLATION FOOTPRINT

The modular setup of the AEB-DE series makes it simple for skid builders to standardize their designs without regard to flow rate and liquid characteristics. A compact modular design adapts to skids with ease. Skid builders simply outfit the installation space

for the specified pump according to the operating data provided. Four pump sizes with identical outside dimensions are available to suit user needs and are capable of bi-directional flow. This flexibility facilitates future variations in needed flow rates with simple changeouts of conveying elements. No cost-intensive refurbishments or adjustments to piping are necessary.

Users have a choice between threaded and flanged pump connections with an optional baseplate.

CIRCOR Confidential & Proprietary



OPTIMIZED FOR SAFETY AND UPTIME

The innovative design of the new suction casing has three additional closed drillings that can be used for various functions.

Customers have the ability to fill the pump, to drain it, or to install additional auxiliaries if needed. Further, the new design of the casing ensures a permanent flushing and cooling of the seal as it is located in the flow of liquid.

Due to this, the pump can also be installed vertically without any risk of harmful dry run. (If required, a quench connection can be offered as a seal option or the pump can be equipped with a gland packing.) To further ensure safe plant operation and preventable breakdowns or damage to the pump, the AEB-DE series can be upgraded with smart dry running protection (ATLS-T1) or a pressure sensor (ATLS-P).

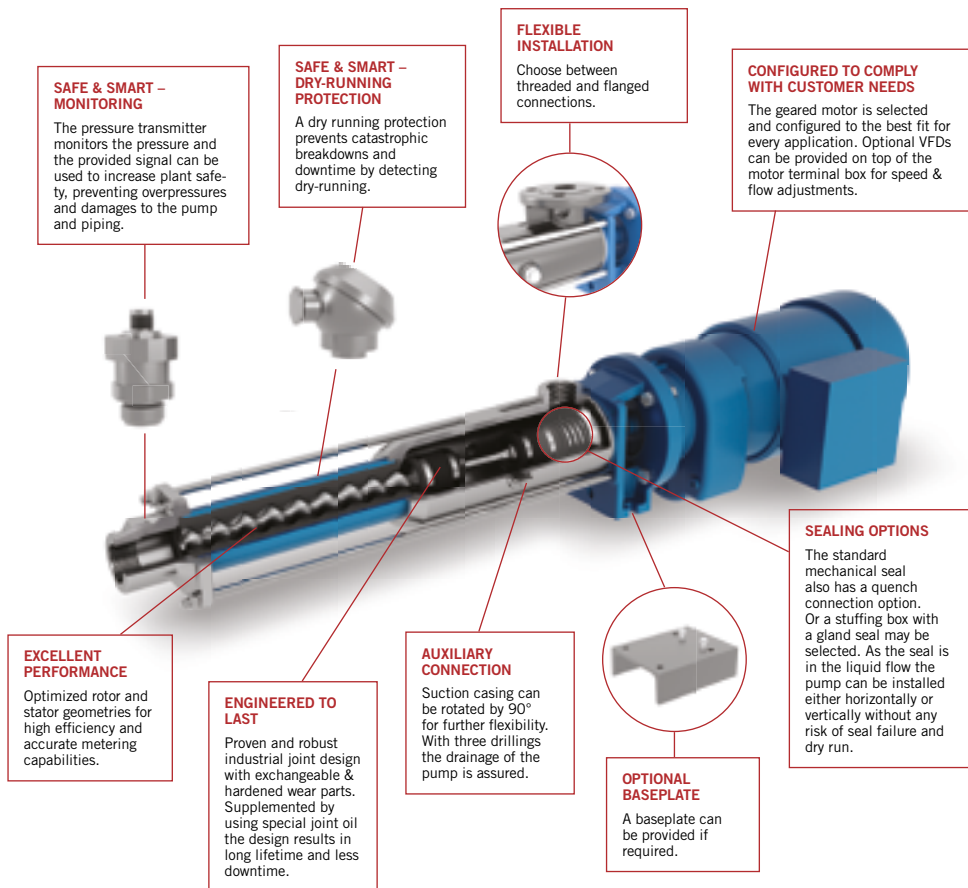

ONE PUMP SERIES FOR MORE OF YOUR DOSING APPLICATIONS

Versatile and compact, the AEB-DE pump series accommodates wide viscosity, flow rate and temperature ranges and delivers reliable high volumetric efficiency. The geared motor is selected and configured to the best fit for every application.

Optional VFDs can be provided on top of the motor terminal box for speed and flow adjustments. The geometry and technical details of key components have been optimized to further improve metering accuracy and performance curve stability. High-grade stainless steel material allows pumps to cover even more applications than before, including:



WATER & WASTEWATER
Polymer, Flocculant



CHEMICAL PROCESS INDUSTRY
Acid, Leachate, Catalysts, Condensate, Additives



PULP & PAPER
Additives, PVOH, Sizing Agent, Starch, Dye, Optical Brightening Agent, Polymer



MINING
Polymer, Tenside, Catalyst



MARINE
Oily water, Urea, Bilge, Seawater



FOOD
Oil, Sauce, Chocolate, Liquor



GENERAL INDUSTRY
Caustic Soda, Glycol, Paints, Glues, Sealants



POWER
Urea, Waste Oil, Slop Oil





CIRCORSMART™

PUTTING CRITICAL DATA AT YOUR FINGERTIPS.



**INSTANT INFO.
IMMEDIATE ANSWERS.**

- Product-specific instruction manuals
- FAQ and troubleshooting tips
- Instructional videos
- Spare part requests
- Material records
- The expertise of product specialists

**PRODUCTIVITY-
ENHANCING FEATURES.**

- > Track maintenance on each product
- > Take detailed notes
- > Attach photos and important file



**THE APP DESIGNED TO MAKE
YOUR JOB EASIER.**

With the recently expanded “North American Pipeline and Hazardous Materials Safety Administration Mega Rule” regulation in USA and the “DIN SPEC 91406 industrial standard” (Automatic Identification of Physical Objects and Information on Physical Objects in IT Systems, Particularly IoT Systems) in Germany, having the necessary data for products like the CIRCOR Pumps now considered a crucial path for operators. With CIRCORSmart, accessing the info you need has never been easier.

GET THE APP

Discover the difference in having immediate access to critical information and product tracking on your operation and its uptime. Download the CIRCORSmart app today.





CIRCORSmart App is the solution to the market needs

- ✔ 24x7 access to critical technical information from any web connected device
- ✔ Easy access to product information wherever there is a mobile connection.
- ✔ Geolocation of assets cross referenced with Serial number and supporting documentation
- ✔ Access to product operation and maintenance videos and supporting documentation
- ✔ Customer service contact details.
- ✔ Spare parts identification to remove any doubts

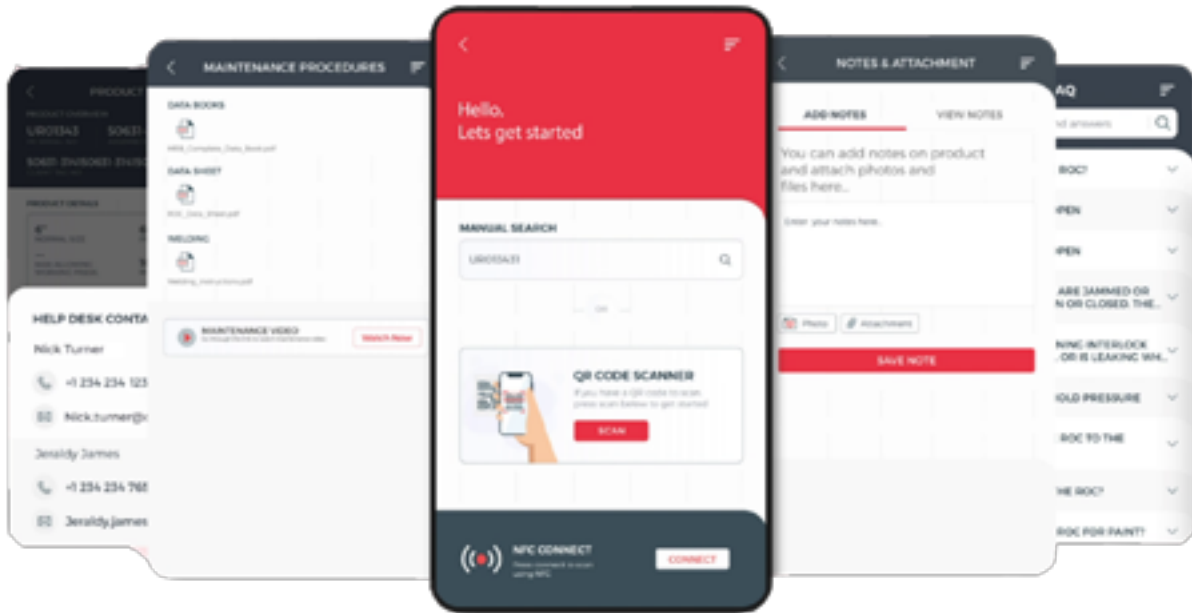

CIRCORSmart™
PUTTING CRITICAL DATA AT YOUR FINGERTIPS.

The **basic** version of the app provides instant access to critical information and product history. The **Pro** version provides additional features like:

- Product specific instruction manuals
- FAQ and troubleshooting tips
- Technical advice
- Spare part requests
- Material requests
- The register of product operators

PRODUCTIVITY-ENHANCING FEATURES:

- Track replacement on each product
- Scan related parts
- Attach photos and important files

INDUSTRY-LEADING INNOVATION.

CIRCORSmart is the first mobile app to offer instant access to critical information and product history. CIRCORSmart's innovative use of QR codes and NFC technology makes it the most powerful tool for product identification and data access in the industry.

GET THE APP

Choose the platform in which you want to download the app. Scan the QR code to download the app or visit the CIRCORSmart app store.

Available on the App Store | **GET IT ON Google Play**

CIRCOR | **Circle of Control**

CIRCOR Confidential & Proprietary

MARKETING UPDATES

ALLWEILER SERVICE PORTAL

We would like to highlight our Service Portal, made for our Channel Partners, where they can retrieve information easily.

Products. When you are working on an offer/project you can find the latest manuals with all facts and figures. Also details around Spare Part you find here.

Marketing. You can download the latest marketing materials we have. This can be brochures, give a way, roll-ups, PP-presentations, 3D animation and even small 3D models of our pumps.

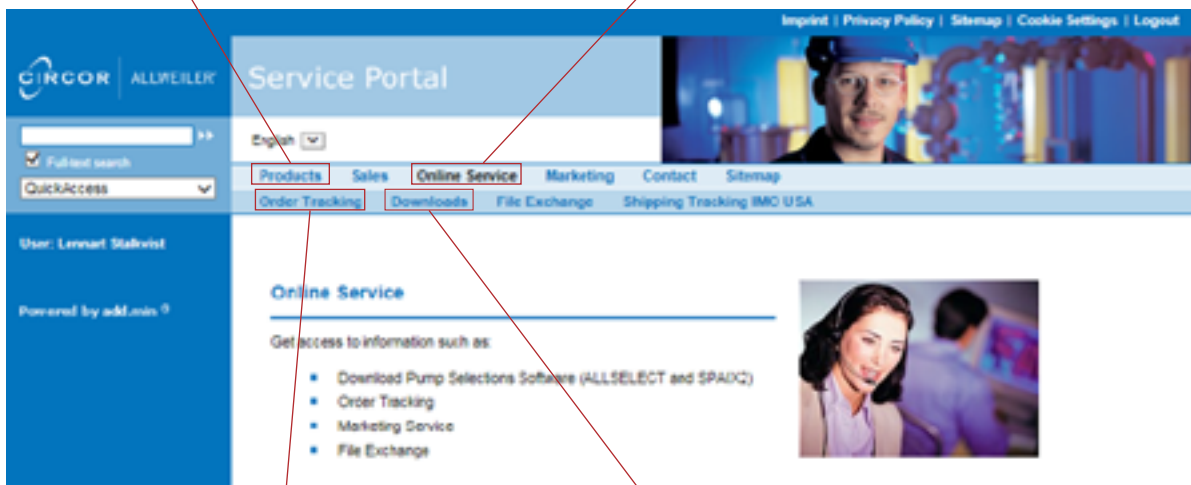

Order Tracking. Here you can get answer on your question, "where is my order?" This is one of the more frequently used functions in the portal.

Downloads. You can download our selection programs **Allselect** and **Spaix2**.



TRAINING 2021

Date	Start Time [CET]	Duration	Module Name and Content	Trainer
Tue 7-Sep-2021	1:00 PM	60 min	Circor company overview	Gunter Connert
Thu 9-Sep-2021	1:00 PM	90 min	Applications and Products Basic Overview	Thomas Reitz
Tue 14-Sep-2021	1:00 PM	60 min	Market module 1: Sewage, Dosing, Food & Beverage, Pulp and Paper	Elvis Kovacevic
Thu 16-Sep-2021	1:00 PM	60 min	Market module 2: Oil&GasProcess Engineering & Chemical Industry	Simon Pistilli Wolfgang Seiberth
Tue 21-Sep-2021	1:00 PM	60 min	Market module 3: Power GenerationHeat TransferTool Machinery	Frank Kahnert Wolfgang Seiberth Jannik Roeben
Tue 23-Sep-2021	1:00 PM	60 min	Market module 4: Commercial Marine & OffshoreNavy	Tamara Buhl Anne Quesnay
Tue 28-Sep-2021	1:00 PM	120 min	Solution & Value Selling	Gunter Connert
Thu 30-Sep-2021	1:00 PM	120 min	Centrifugal Technology	Jürgen Gebhard
Tue 5-Oct-2021	1:00 PM	90 min	Centrifugal Selection & pricing	Udo Stitz
Thu 7-Oct-2021	1:00 PM	120 min	PC Pump Technology	Elvis Kovacevic
Tue 12-Oct-2021	1:00 PM	90 min	PC Selection & Pricing	Marc Foginski
Thu 14-Oct-2021	1:00 PM	120 min	3-screw Technology	Marko Mandac Henrik Wikström
Tue 19-Oct-2021	1:00 PM	90 min	3-Screw Selection & Pricing	Christoph Kaiser
Thu 21-Oct-2021	1:00 PM	120 min	Gear Pump Technology	Bob Limper
Tue 26-Oct-2021	1:00 PM	120 min	Twin-Screw Technology	Axel Jaeschke
Thu 28-Oct-2021	1:00 PM	60 min	Twin-Screw Selection & Pricing	Stefan Ladig
Thu 4-Nov-2021	1:00 PM	90 min	SPAIX Selection Tool for Centrifugal Pumps	Joachim Bruetsch
Tue 9-Nov-2021	1:00 PM	120 min	ITML usage	Carlos Sanz



ALLWEILER®
IMO®
HOUTTUIN®
ZENITH®
WARREN®
TUSHACO®