

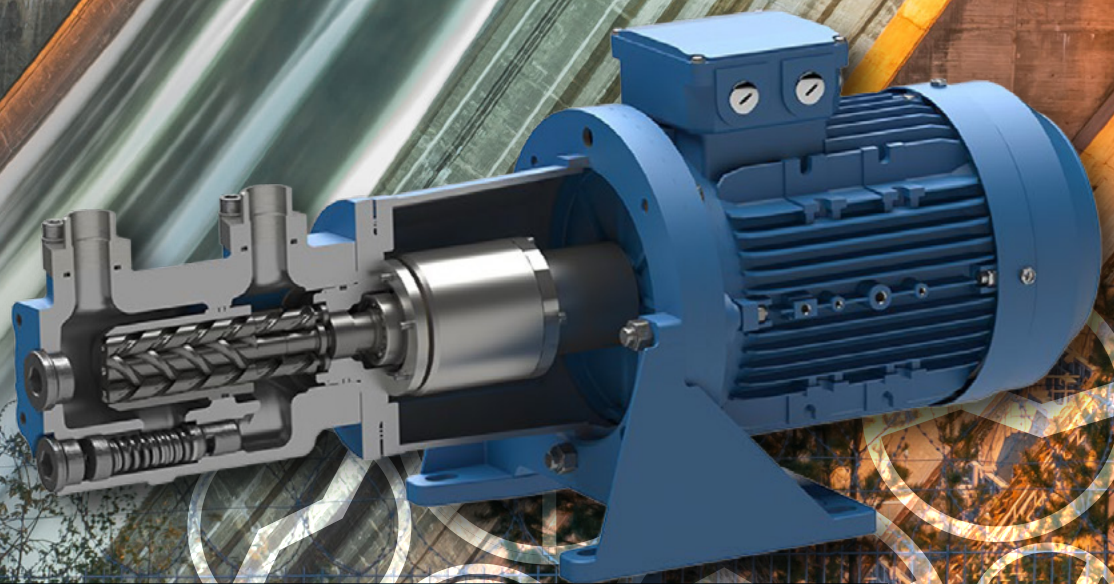

SALES NEWSLETTER

Industrial Pumps EMEA & APAC

N2 2021



ALLWEILER AFM THREE-SCREW PUMP



Dear all,

When I wrote my last letter about half a year ago, I was hoping that by Christmas the pandemic would have moved more out of focus than it actually has. However, the impact has shifted somewhat. After a quite spectacular market recovery in the first half of the year, we are now confronted with significant imbalances in the global supply chain. These are causing not only shipment delays but also unprecedented material inflation, which suppliers and manufacturers can't just absorb but are passing on to their customers. I am sure you experience this in your daily lives, both personally as well as professionally. In such times it is important for us that we have a thorough understanding of our value proposition and that we are able to articulate it when talking to our customers.



In this context let me point out an article featured in this edition. In the Products & Solutions section you will find a comprehensive overview on the benefits of three-screw pumps, in particular in comparison with gear pumps. As three-screw pumps are such a central part of our product portfolio, CIRCOR is well positioned to satisfy a broad range of customer needs in different markets and for different applications, where three-screw pumps are a preferred solution. You will likely also be interested in hearing that we are accelerating our digital agenda as you will be able to see on the last pages of this Newsletter. Whether it is our new web page that we will be launching early next year, our digital showroom or our 'Govies', i.e. next generation 3D product presentations. These are all important steps in adapting the way we interact and do business to a much changed environment. And there is clearly more to come on this subject in the next couple of years.

While the outlook for 2022 is still somewhat volatile, there is no doubt in my mind that the market will offer attractive opportunities for us, maybe at times in areas we have not been fully anticipating. Let's remain agile while also executing on our identified strategic growth opportunities around regional expansion, Progressing Cavity Pumps growth as well as Aftermarket. I am counting on all of you to deliver another year of excellent growth in 2022.

Best regards

Daniel Stirpe
VP/GM Industrial Pumps EMEA & APAC

CIRCOR Confidential & Proprietary



SECTION

1

SECTION

2

SECTION

3

SECTION

4

SECTION

5

INSIDE CIRCOR

New Head Office in India

New Aftermarket Sales Managers

Allweiler participates in the Heimattage 2021

Dramatic supply situation leading to price increases

CUSTOMER FOCUS

Success story NPP Akkuyu

Success story Aftermarket

Success story Commercial Marine

Success story Navantia

SALES CHANNEL

New Channel Partner GN TECNOPOMPE

Long-time Authorized Channel Partner F3F

Channel Partner Sales Meeting

PRODUCTS & SOLUTIONS

Why a three-screw pump?

Advantages of three-screw pumps vs. gear pumps

MARKETING UPDATES

New animated sales tools | Govies

New digital showroom

New web page

CIRCOR Confidential & Proprietary

NEW HEAD OFFICE IN INDIA

We recently inaugurated our new Head Office in India. The 10,000 sq.ft area is based out in the 'City of Lakes' Thane near Mumbai.

The new office is in a commercial complex and includes capacity for 100 employees, in contrast to the earlier office which had a capacity for 60 seats only.

The CIRCOR India Head Office today is a vibrant workspace that extends to our employees a warm feeling to be at work. It's a well-regarded facility that offers to its employees a safe work zone with equal focus on physical and mental wellbeing. We have crafted a wellness room, recreation zone, breakout areas and adequate meeting rooms maintaining all safety precautions and Covid 19 guidelines in view.



Traditional lighting of ceremonial lamp



Ribbon cutting



Reception



Product display

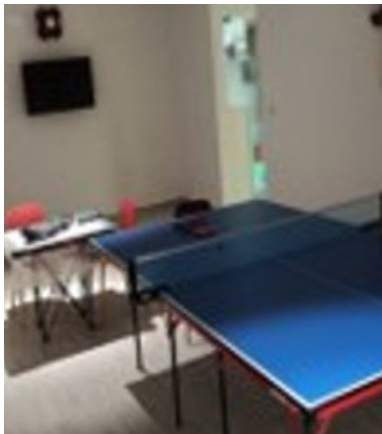

Recreational area



Break out area



Work stations

CIRCOR Confidential & Proprietary



NEW SENIOR DIRECTOR AFTERMARKET



ALEXANDER SCHAEFER

Where are you located?

I'm located in Radolfzell / Germany.

When did you first join the company?

In July 2021.

For which territories and markets are you responsible for as Sr. Director AM & Sales?

My responsibility covers the global aftermarket and service activities of Pumps EMEA & APAC for the Commercial Marine, Industrial and Defense business.

What do you love about your job?

Having a great team, great products & brands and great opportunities to grow.

How do we win in the minds of our customers, beating out our competitors?

The simple answer is being better than our competition: longer lifecycle, global and local support, safe products. Here we have a lot of opportunities.

How do you manage to stay in contact with your channel partners during the Covid-19 pandemic?

Besides of emails and phone calls I communicate mainly remotely via video conference. However, as regulations with Covid 19 allow travel in certain regions, I have also started visiting customers face to face.

What else would you like to share about yourself?

I am passionate about my family, biking & hiking, music and veteran cars.

NEW CHANNEL SALES MANAGER AFTERMARKET



LENNART STALKVIST

Where are you located?

I'm located in Stockholm Sweden.

When did you first join the company?

I joined IMO AB in 2008. My initial role was to sell magnetic coupled pumps to the marine industry in Europe.

For which territories and markets are you responsible for as Channel Sales Manager Aftermarket?

I'm responsible for helping our Channel Partners in EMEA to sell more of our spares and replacement pumps.

What do you love about your job?

To work in an international environment and the variation of challenges that comes with the role. The best is when meeting customers face to face, so I look forward to doing that during 2022, hopefully. I have always worked with international sales.

How do we win the minds of our customers, beating out our competitors?

By listening to customers and supporting them swiftly. Being honest is also important. The quality of our product is usually never questioned. It's just the delivery we need to focus on.

How do you manage to stay in contact with your channel partners during the Covid-19 pandemic?

MS Teams has been my best tool and it works well.

What else would you like to share about yourself?

I like everything with a motor e.g. motorcycles, cars, boats.



ALLWEILER PARTICIPATES IN A TWO-DAY EMPLOYER FAIR

The “Heimattage” event has existed since 1978 and is hosted every year by a different town in Baden-Württemberg to highlight the different regions and specialties.

This year the “Heimattage” took place in Radolfzell. Allweiler has a longstanding history with the town and its community, so we were delighted to take part in the two-day employer fair on the weekend of July 3rd and 4th.

The fair was open to everyone and we were able to showcase our products, career opportunities as well as our apprenticeship program. It was a great success and we were visited by over 7500 people.



CIRCOR Confidential & Proprietary



DRAMATIC SUPPLY SITUATION LEADING TO EXTRA

Only recently has the global economic outlook appeared to be so positive: The slowdown in global growth during the third quarter of 2021 was considered a temporary response to the recent wave of COVID-19 virus infections. Growth was expected to revive over the next two quarters, presenting good opportunities for strengthening the sales funnel further & to increase the orderbook through Q1/2022.

Manufacturing continued to outperform services, despite widespread problems with the supply of components to many factories, helping to keep the overall pace of Eurozone expansion at one of the fastest for 16 years. But now the disruption of global supply chains and the systematic shortage of raw materials, packaging materials and transportation capacities is driving manufacturers' costs to a record highs.

The shortage of supply relative to demand has resulted in sharply higher prices for many inputs. Global manufacturing PMI input prices have hit a ten-year high since mid-2021. Global manufacturing PMI delivery times index also shows a steep rise in delivery times (see graph).

The highest materials price pressure is observed in countries where the lowest supply meets the strongest demand, namely in Europe, UK and the US (see graph). Supply chain constraints remain a recurring theme on a global scale.

Price pressures remain elevated. As supply continues to severely lag demand, it has been a sellers' market for many materials into end-2021.

The above developments are affecting all major players in the industry. And despite all logistic and commercial precautions, targeted counteraction across our global sourcing and manufacturing footprint, careful planning and pragmatic workarounds, the significant cost increases are also hitting CIRCOR hard.

As a consequence, CIRCOR was forced to increase prices as of October 1.

Executing this price increase is a major organizational challenge for CIRCOR and for the Authorized Channel Partners. In the light of the recent economic developments, however, the price increase was unavoidable.

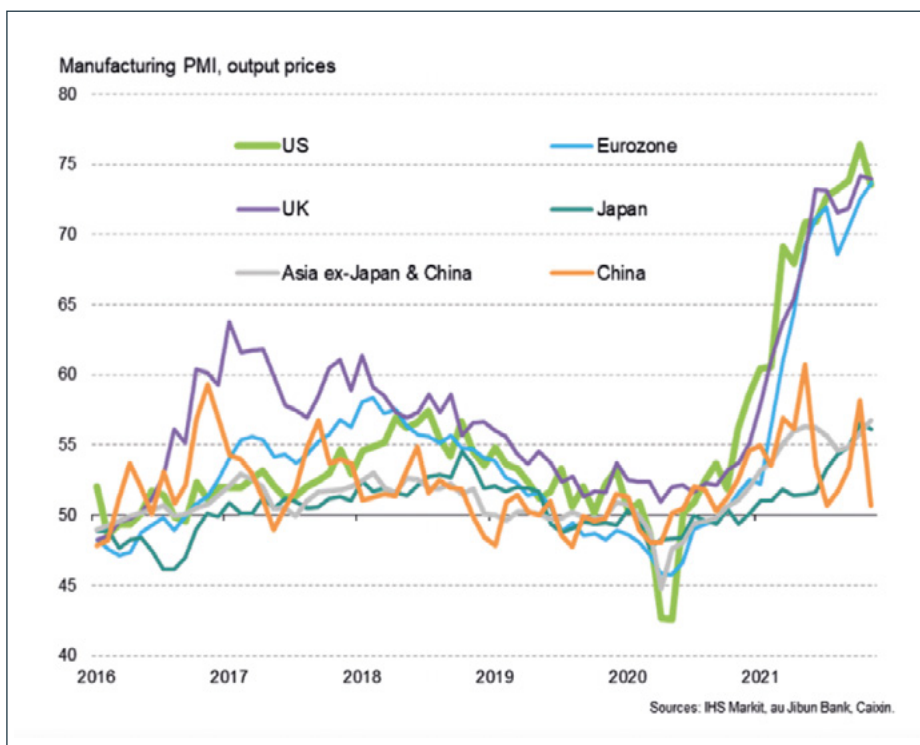

CIRCOR Confidential & Proprietary



ORDINARY PRICE ADJUSTMENTS IN THE INDUSTRY

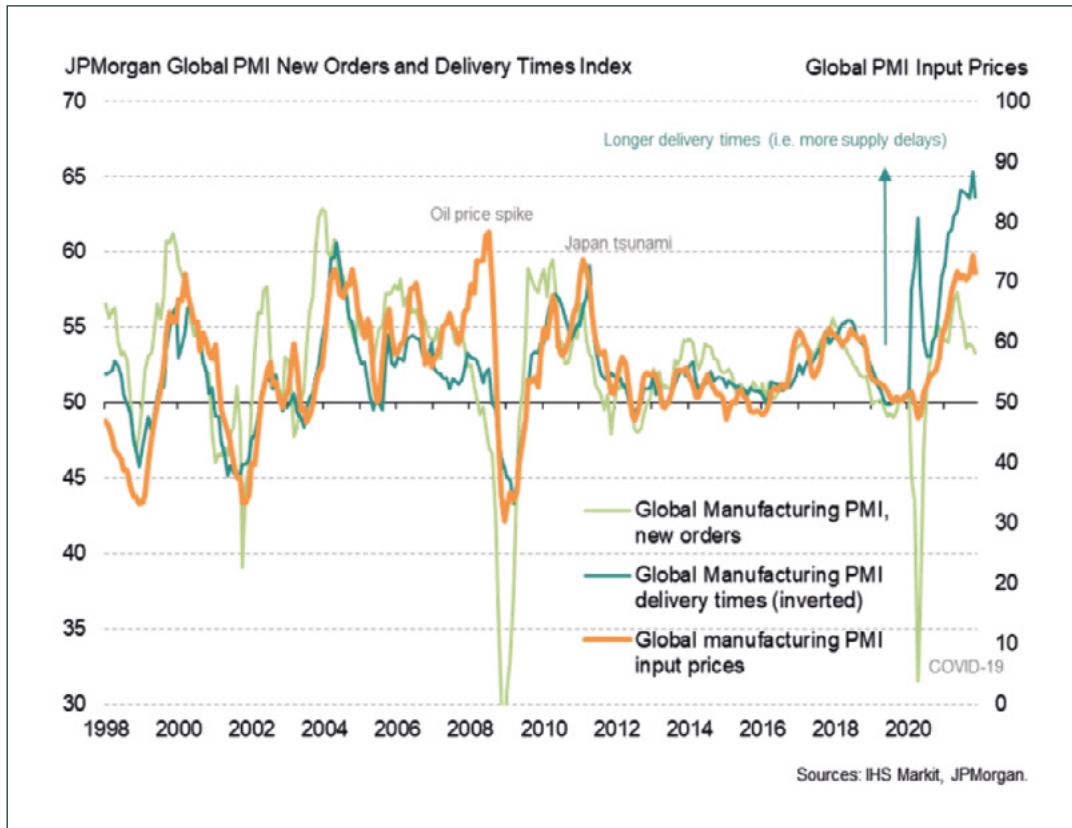

Source: IHS Markit. Updated September 14, 2021



CIRCOR Confidential & Proprietary

Success Story Power

NPP AKKUYU

Pumps for Akkuyu Nuclear Power Plant

Allweiler was selected and certified as supplier for Lube Oil-, Seal Oil- and Stator Cooling Pumps for 4 blocks of WWER-1200 design reactors built at the south coast of Turkey.

The pumps of the NSS, SNGS and CNH-B series were selected for their reliability and durability and of course it was imperative to comply with the demanding specification requirements in terms of design engineering, quality assurance and documentation.

Allweiler can look back on decades of experience in nuclear power plant applications and has hundreds of references in the Nuclear Industry.

The team is proud to contribute to the safety and availability of this new large turbine-generator units.

Customer Name: Rockfin, Poland

Product description: Allweiler Centrifugal and three-screw pumps

Application: Auxiliary systems for Nuclear Power Plant Akkuyu (Turkey)

- Seal Oil Pumps (Allweiler SNGS)
- Stator cooling water pump (Allweiler CNH-B)
- Lube Oil Treatment (Allweiler SNGS)
- Turbine Lube Oil (Allweiler NSS)

Why we won?: Components in nuclear power plants are of course subject to the highest safety standards. High quality, and operational safety, as well as, good service over the life time of the equipment are key requirements. We advised Rockfin and their customer GE closely regarding technology and documentation, all of which established a close relationship between the three parties.

Long term implications: GE will continue to build nuclear power plants around the world in the future. With our qualified cooperation we will be the first point of contact for other projects. This order will create an aftermarket demand for the next twenty years.

Individual recognition: Technical Sales Team: Sarah Werner, Christoph Kaiser, Stefan Krause.



CIRCOR Confidential & Proprietary



Success Story Service

SERVICE TEAM WINS HOUTTUIN ORDER IN SAUDI ARABIA



An Italian manufacturer supplied twin-screw Heavy Fuel /Slop Oil Pumps to Jeddah South Thermal Power Plant (JSTPP) back in 2014.

The end user (Saudi Electricity) was facing frequent mechanical seal leakages and reliability issues from these pumps, a problem causing them extended downtime and to exceed their maintenance budget. The manufacturer was charging heavily for spares each time without identifying the root cause of failures. Due to the strong service support provided by the local CIRCOR service team for another SEC plant (Rabigh PP), the end user was recommended to approach CIRCOR. The CIRCOR Aftermarket Sales Manager M Saad and distributor (YBA Kanoo) immediately arranged a visit to the customer site to identify the root cause and to

recommend the optimal pump solution from the CIRCOR product range.

As a result of the quick response time, local service capability and technical expertise CIRCOR was able to convince the customer to purchase two new Houttuin twin-screw pumps 236.40-088 Series for replacing the incumbent units.

There are 20 more larger twin-screw pumps installed where the end user is facing high maintenance expenses and lack of local service capabilities from the incumbent OEM. CIRCOR Service team is in discussions with SEC and the Contractor for further pump replacements (with a potential exceeding \$1M for replacing competitor pumps). This is a great example of success resulting from relationships built with customers.



Two-screw pump Houttuin 236



CIRCOR Confidential & Proprietary



Success Story Commercial Marine

ALLWEILER NORWAY SECURED THE ORDER FOR TWO J70 CARGO PUMPS AT WUHU SHIPYARD

Overview

A Canadian shipowner wanted a new green asphalt tanker design with submerged cargo pumps. Such a ship design didn't exist in the market yet. This new tanker design was developed by Swedish design office FKAB. The idea was to install submerged cargo pumps so no cargo pump room is needed anymore. Cargo pump rooms of standard asphalt tankers were always problematic since the US Coast Guard take samples every year to check if there was a cargo spill. Pollution was very difficult to avoid. Additionally, there were costs incurred for the yearly inspection. The submerged pumps are inside the cargo tank so no inspection is needed anymore and no cargo spill can happen.

The Challenge

The challenge was to develop a new ship design which integrate submerged cargo pumps to reasonable prices. Standard asphalt tanker design includes 2 dry installed cargo pumps. With one submerged cargo pump in each tank 8 submerged cargo pumps would have been needed.

The Solution

IMO US promoted in early stage the Warren submerged J70 pump towards the Canadian shipowner. Parallel Allweiler Norway promoted the Warren J70 pump towards the ship design office FKAB in Sweden which made the new tanker ship design. In cooperation with Allweiler Norway, FKAB developed a tanker design where 4 tanks are connected to one cargo column. In every cargo column was one J70 pump integrated. As a result this new tanker design has only 2 submerged cargo pumps instead of 8.

At a later stage, when Wuhu Shipyard in China was chosen to build this new asphalt tanker, Allweiler Norway developed together with FKAB and supported by US engineering team the detail cargo pump specification for the shipyard. Special wishes from the Canadian Shipowner based on experiences on their barge were also implemented in the shipyard specification.

Allweiler Norway and our local partner Marinequip already had a good reputation at Wuhu Shipyard

from previous projects. We supplied several Offshore Supply Vessels and secured also 2 standard asphalt tankers with dry installed cargo pumps in 2021.

The Result

Allweiler Norway secured the order for two J70 cargo pumps over total 600K USD at Wuhu shipyard for delivery mid 2022. This project we won due to the great cooperation between CIRCOR entities Allweiler Norway, IMO, Warren and local strong partners FKAB in Sweden and Marinequip in China. Marinequip will make also the commissioning of the cargo pumps at Wuhu shipyard.

This new asphalt tanker design is a milestone in new ship development. The problem with one submerged cargo pump each tank was solved by installing cargo columns which lead to reduction from 8 to 2 cargo pumps. This new ship design is competitive with standard design with dry installed cargo pumps. For future tankers the cargo pump specification is written based on the J70 pump, so CIRCOR will have significant advantage to win these projects.



CIRCOR Confidential & Proprietary



Success Story Navy

NAVANTIA



Overview

Navantia shipyard based out of Ferrol is awarded to build the new multipurpose and anti-submarine F110 class frigates for the Spanish Navy for a total of five new shipsets to be built between 2022 & 2030+. This surface ship will replace the previous F100 dated from early 90's. Amongst this domestic ongoing program, Navantia intends to export these frigates for export projects as they did successfully in the past with the Australian Navy.



The Challenge

The challenge was our ability to offer the complete package of volumetric and centrifugal pumps adapted to their specific needs such as shock, noise and vibrations and special mounting arrangements together with the special heavy documentation pack necessary for such newly built programs. All this in a competitive landscape and a customer with whom we had no contract references up to now.

The Solution

During the three months of bidding phase, our Defense sales team worked intensively with engineering to offer the customized solutions to fit perfectly Navantia's needs. Our flexibility and the proactivity of our exchanges, facilitated by a terrific support of our local partner F3F, led the customer to update the specifications according to the insights we were suggesting especially from an acoustic stand point.

The Result

After intense negotiations made more difficult in the current raw material frenzy environment cumulated with customer desire to contractualize firm prices for the total 5 shipsets program with deliveries up to 2028, CIRCOR France has finally secured this million dollar project for the full pump package of 41 pumps per ship engaging into a long-term partnership with an important European defense shipbuilder.

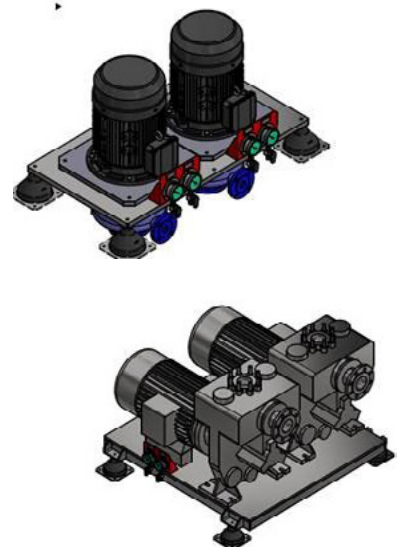

CIRCOR Confidential & Proprietary

SALES CHANNEL FOCUS

NEW AUTHORIZED CHANNEL PARTNER IN ITALY: GN TECNOPOMPE

GN Tecnopompe was founded in 1990 by Giovanni Naoni as a service provider for pumps and is based near Brescia, about 40 km East of Milan. Their main area of activity is Lombardy.

During the years they extended their scope also to the sales and distribution of various pumps manufacturers, thus gathering a broad experience in numerous operating conditions, and on the special needs and challenges specific to each different industrial sector.

Tecnopompe covers the entire service and maintenance, and they rely on an extensively equipped workshop at their premises.

Thanks to their own service vehicles, complete with a full set of tools and instruments they can offer repair and service operations directly at customer's site.



In more challenging situations, if required, they can also take advantage of their crane trucks to remove even the larger pumps and transfer them to their workshop, where any kind of maintenance activity can be carried out.

One typical application where this is needed is for example the maintenance of well pumps, in which case, they extract the submerged pumps with their crane, to carry out cleaning and service.

Their service scope ranges from complete disassembly of the pump, revision, overhaul, replacement of defective parts, mechanical repair of components, replacement of worn out or failed parts, reassembly and final painting of the repaired pump. Before the delivery, all pumps undergo a functional test.

CIRCOR Confidential & Proprietary



Following completion of a job, Tecnopompe issues a complete repair certificate, describing the issue identified and the repair carried out.



Tecnopompe also is equipped with a series of instruments extending their offering to vibration measurement, noise check, leakage discovery, laser alignment.

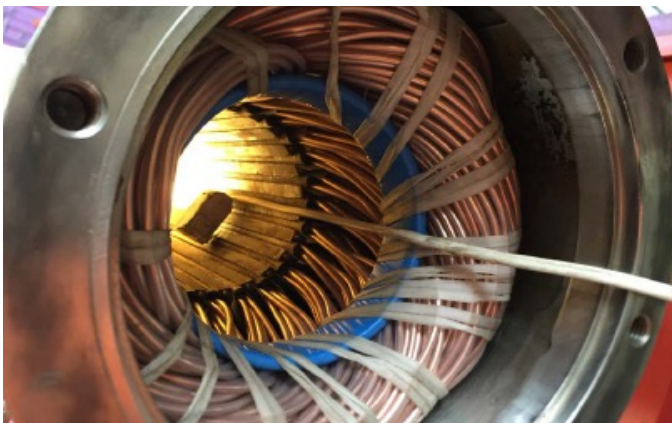

An additional offering is the rewinding of various types of electric motors.

Thanks to their detailed knowledge of the industry in their region CIRCOR Italy will have great support in developing its market share.

Furthermore, we are excited to be able to offer to our customers an excellent maintenance and repair service thanks to Tecnopompe's capability. We are sure that thanks to their technical support and regional proximity we will be able to intervene rapidly and effectively, increasing the value that CIRCOR Italy can provide to their customers.

CIRCOR Confidential & Proprietary



F3F – A LONG TERM SUCCESSFUL AUTHORIZED

Our partner F3F, established in 2010 and located in Barcelona, Spain, is a team of 14 people, 9 of which are sales engineers. They are specialists in hydraulic pumps, with years of experience in advising and installing this equipment in industrial process plants in Spain, Portugal, Chile, Bolivia and Peru, where they are distributor of CIRCOR (brands represented: Allweiler, IMO AB, IMO USA, Zenith, Warren, Houttuin). F3F capabilities comprise design, installation, service and maintenance of CIRCOR pumps in their region of competence, with over 750 of our pumps sold per year.

F3F have successfully developed numerous projects within different industries, with special focus on Water Treatment,

Oil & Gas, Power Generation, Naval and Mining, among others. Their latest greatest successes: PC pumps for a desalination plant in Saudi-Arabia built by Spanish EPC Abengoa and a large pump-package consisting of centrifugal pumps, PC pumps, three-screw and twin-screw pumps for the Spanish shipyard Navantia.

F3F is strongly focused on creating value to their customer. Their team travels 36.000 km / year to regularly visit their over 1.500 Allweiler customers.

Their technical experience and customer intimacy make them a highly appreciated partner for the industry and for CIRCOR.

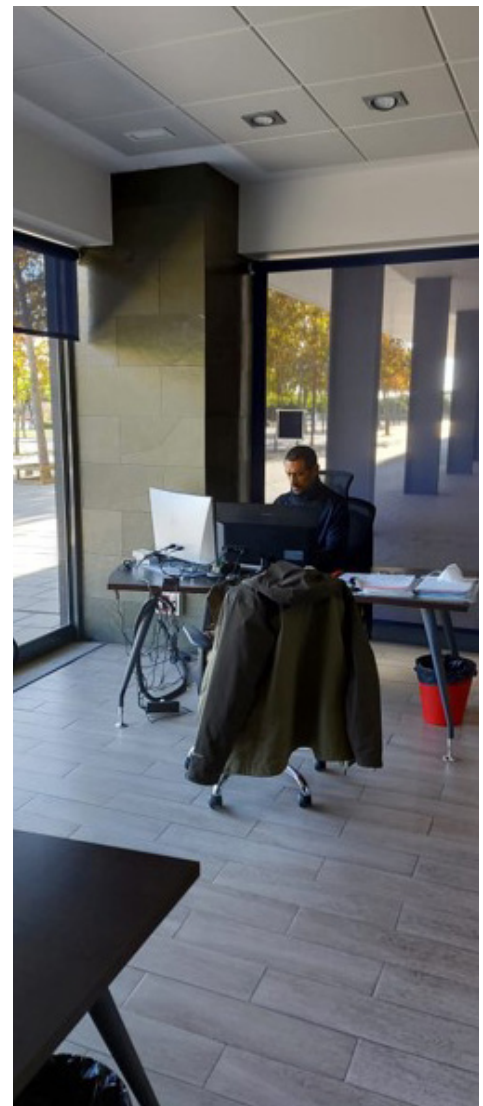
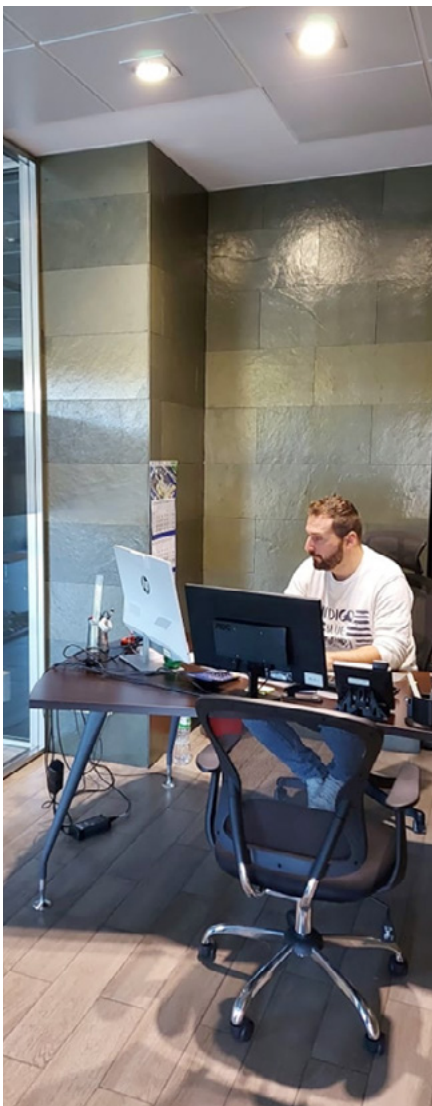

CIRCOR Confidential & Proprietary



SALES CHANNEL PARTNER

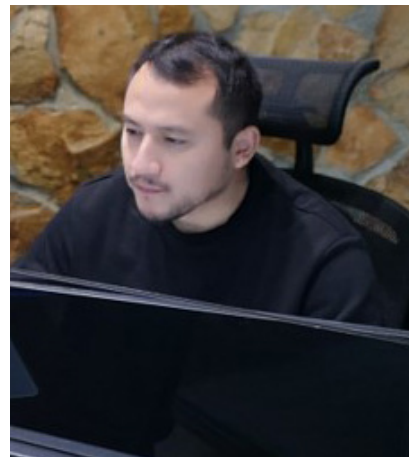
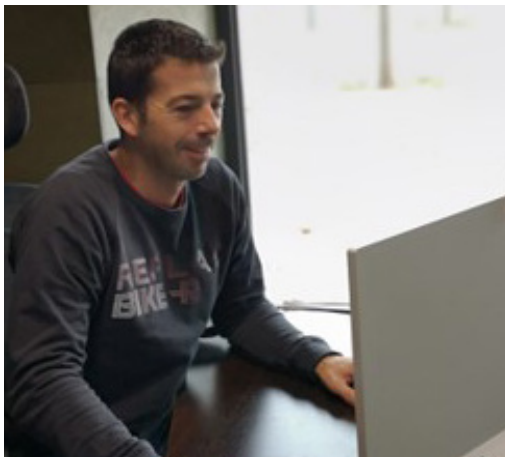

CIRCOR Confidential & Proprietary



Staying informed

INDUSTRIAL PUMPS EMEA CHANNEL PARTNER MEETING

First held in 2020 our EMEA General Industry Channel Partner meeting has been connecting our Channel Partner Network across continents. The new online format has proven to be an efficient mean to address current topics and review the collaboration with our partners.

With challenges in Supply Chain, market feedback to highlight projects we have had many recent, relevant and mixed topics to discuss. This has been an opportunity to review the strengths of our organization and products. The introduction of Alexander Schäfer in his role as leader of Aftermarket & Service, Jannik Röben's insight into Strategic Business Development at CIRCOR as well as the plans to strengthen our collaboration with our Channel Partners have been perceived as exciting topics. We thank the approximately 50 participants for a lively event and active discussion. We are excited about the journey ahead of us, in close co-operation between CIRCOR and the Authorized Sales and Service Channel Partner network.



CIRCOR Confidential & Proprietary

PRODUCTS & SOLUTIONS

WHY A THREE-SCREW PUMP?

Three-screw pumps can increase reliability, which means higher uptime, longer maintenance intervals, and longevity. This means savings for machinery lubrication, crude oil transport, hydraulic power transfer, fuel oil transport and machine coolant applications.

The modern-day three-screw pump design was invented in 1923 by Carl Montelius who, along with Swedish financier Bengt Ingeström, founded Imo AB (today a part of CIRCOR). The pump operates on the same principle of intermeshing screws as the two-screw pump, but the three-screw design uses a centrally located primary drive screw, or power rotor, which intermeshes with two secondary sealing screws, or idler rotors.

How it works

The intermeshing of the threads of these rotors, along with the close fit of the surrounding housing, creates a moving labyrinth seal, which captures the fluid and transports it axially. The enclosed volume containing the fluid is referred to as a fluid closure (see Figure A). The pumping element does not pre-compress the fluid, but rather transports it from the suction side of the pump to

the discharge port in a smooth, continuous manner. It is the fluid closure concept that provides the three-screw pump with its positive displacement capability.

Symmetrical pressure loading on the power rotor with such small forces eliminates the need for bearings to absorb radial forces. The idler rotors generate a hydrodynamic film providing radial support like journal bearings (See Figure B). Axial loads on the power rotor and idler rotors, created by differential pressure, balance them hydraulically with such small forces that they can be handled by a single ball bearing on the power rotor. This dramatically increases the life of the pump and simplifies the service.

Three-screw pumps come in many configurations and sizes, enabling them to serve as a replacement when other pumps are not performing. They can be easily retrofitted into existing systems.

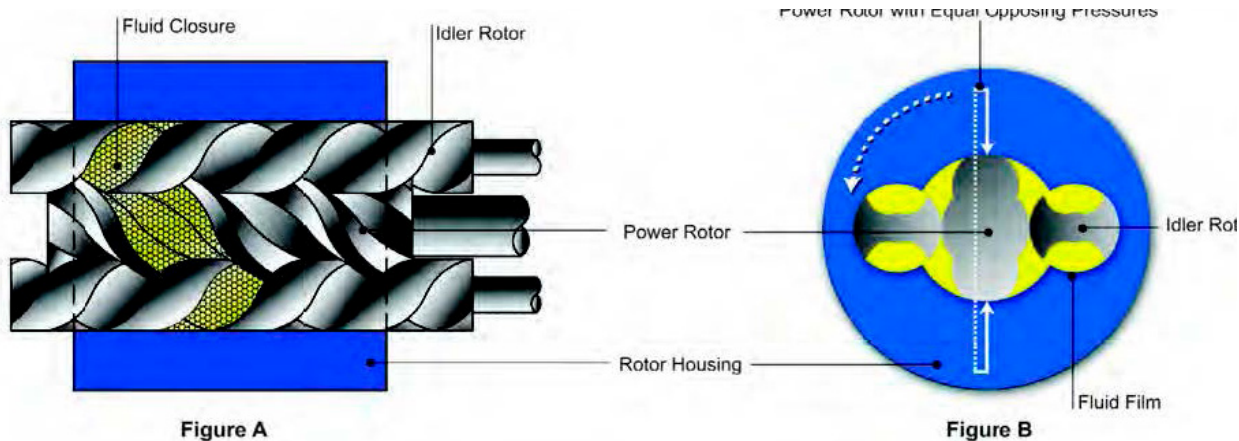

It is the fluid closure concept that provides the three-screw pump with its positive displacement capability.

CIRCOR Confidential & Proprietary

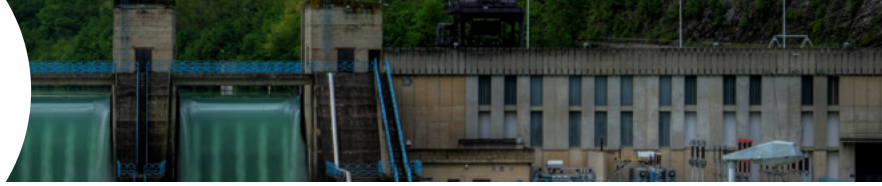

Three-screw pump design

Three screw pumps are ideal for clean, lubricating fluids. Fluid film thickness/operating clearance is typically smaller than that of a two-screw design, giving higher efficiencies and higher pressure capabilities than a two screw pump, providing that the viscosity is adequate and the fluid is clean enough to avoid disruptions to the internal fluid film.

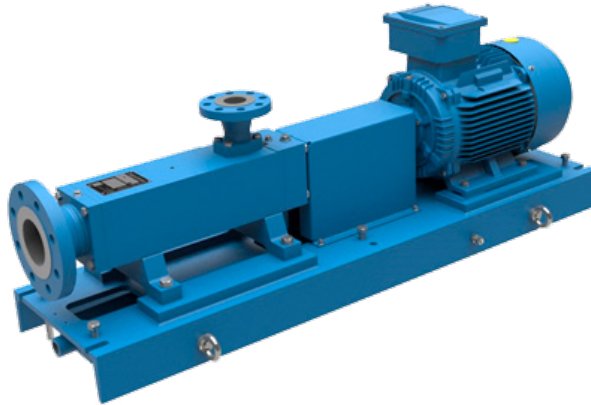

Benefits

The simple design of a three-screw pump: just three rotating parts and one shaft seal, offers advantages for a variety of industries and applications. Some of the primary advantages to three-screw pumps include:

- **Steady flow.** Even though the system pressure might fluctuate, the output flow is stable thanks to the three-screw pump design.
- **Excellent suction lift.** Compared to other pump designs with similar output flows the capability of handling negative inlet pressure is outstanding. This is due to the small peripheral diameter of the rotors and low axial velocity of the fluid. The three-screw pump has an inherent advantage in negative suction pressure applications, allowing the pumping of higher viscosity fluids at much higher speeds than other pumping technologies.
- **Higher-pressure boost capabilities.** Even when handling low-viscosity fluids as low as one centistoke, the high pressure is kept. This advantage is due to the small operating clearances between the rotors.
- **Pulse-free flow.** The pumping element geometry eliminates the requirement for pulsation dampeners often found in systems employing other pumping technologies. Pulsation-free flow allows output condition management that's critical to a variety of applications, such as precision hydraulic controls and fuel metering for gas turbine atomization.
- **Extremely low noise and vibration.** The rotor profile in the screw pump provides a smooth and continuous output flow that greatly reduces pressure pulsations. The result is lowered airborne, fluid-borne and structure-borne noise, typically less than 75 db(A).
- **Highly energy efficient design.** Tight internal clearances, coupled with a design that allows for minimal input power in relation to output power, results in high energy efficiency.
- **Low power consumption while operating on high viscosity fluids.** This is due to the small peripheral diameters of the rotors and low fluid axial velocities reducing fluid shearing within the pump.
- **Long service life due to non-contacting pumping elements by means of hydrostatic and hydrodynamic fluid films, axially balanced rotors, and top-notch metallurgy.**

Maintenance Tips

Because wear is a natural occurrence with rotating equipment, to ensure maximum equipment life, personnel should pay attention to the following:

- **Filters and strainers:** Periodically check for cleanliness and clean or replace as necessary to protect equipment from damage due to pressure drops across clogged or dirty elements.
- **Foundation and hold-down bolts:** Check for tightness at least every six months.
- **Alignment of pump and driver:** Check and correct, if necessary, every six months, or more often if your system experiences an unusual amount of vibration or large variations in operating temperatures.

CIRCOR Confidential & Proprietary



SERVICE INTERVALS

The intervals for inspection and replacement of wear parts vary greatly with the properties of the pumped liquid and can only be determined by experience.

Pumping liquid which contains abrasive materials, or liquid that is corrosive, will significantly increase service life and call for shorter service intervals.

Wear in the pump may be indicated by visible leakage, noise & vibrations, loss of capacity or reduction in flow/pressure.

- **Bearing:** Three-screw pumps can be designed either with internal or external bearing. With internal bearing design, it is lubricated by the pumping liquid. For external bearing design, lubricate as specified in the instruction manual. Check often for noise and/or abnormal vibrations and rough operation; if noted, stop operation, and replace the bearing.
- **Shaft seals:** Recognize that a small amount of seal leakage (about 10 drops per hour per seal) is normal and necessary. Visually check equipment for signs of damage or leakage from shaft seals, gaskets and O-rings and be sure all connections are tight. If the 10 drops per hour per seal is exceeded, shut down equipment and repair or replace with a seal compatible to the pump's operating conditions, as shaft seals have a finite life.
- **Rotors:** If there is a significant loss in capacity and/or pressure, the tight internal clearance between the rotors has most probably increased and the rotors need to be replaced.

ADVANTAGE THREE-SCREW VERSUS GEAR PUMPS

Why using a three-screw pump vs. an external gear pump? (this is NOT about precision gear metering ...)

As CIRCOR, we manufacture both, three-screw and gear pumps. While our gear pump portfolio includes internal gear pumps as well as high precision metering gear pumps focusing on specialty segments, our three-screw portfolio competes additionally with three-screw pumps from other manufacturers with generic external gear pumps on daily basis. Especially in lube- or hydraulic oil applications, gear pumps are often used, as low price and small footprint matters to customers. The following guidelines should provide you with some arguments to sell a three-screw pump and explain what potential problems customers might face using a gear pump and what advantages three-screw pumps have that can solve these problems.

Pulsation

- **Problem:** Very low pulsation is important.
- **Solution:** **three-Screw** pumps have a pulsation of less than 3%.
- **Background:** Basically, both solutions do not have high pulsation. However, the three-screw pumps pulsation is even much lower. The spindle profile creates a continuous, gentle flow rate, which according to studies leads to a pulsation of less than 3% at operating pressure. Gear pumps have a pulsation of approximately 15%.

Efficiency

- **Problem:** In high viscosity applications the efficiency matters and the gear pumps efficiency is low.
- **Solution:** three-screw pumps have a low power consumption with high viscosity fluids.
- **Background:** The small peripheral diameters of the rotors and low fluid axial velocities reduce fluid shearing within the pump, therein reducing power consumption while operating on high viscosity fluids.

CIRCOR Confidential & Proprietary

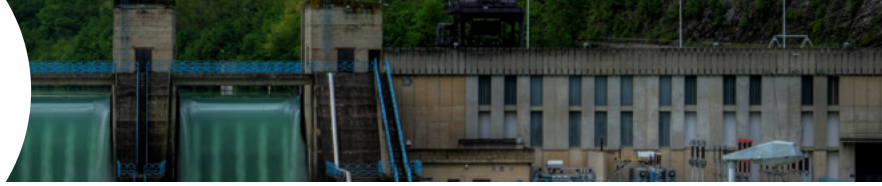

Lifetime

- **Problem:** The customer is looking for a pump with a long lifetime.
- **Solution:** Three-screw pumps have less wear and a longer service life. Considering the total cost of ownership, the higher initial cost for a three-screw pump is quickly absorbed by less need for expensive maintenance or pump replacement.
- **Background:** There is one major difference between a gear and a three-screw pump: The gear pump does have metal to metal contact, the three-screw pump does not. Additionally, in a gear pump radial load bends the shaft. This adds force to the mechanical seal and bearing, making them wear faster. Also a gear pump has axial thrust loading. In three-Screw pumps, radial loading is eliminated, so axial thrust is often eliminated as well. The hydraulic load on components to generate flow and pressure is distributed over a longer screw length which consequently is causing lower load on the components.

Due to that, screw pumps typically provide operational lifetimes which exceed other technologies with most fluids and in most applications.

NPSHa / low suction pressure

- **Problem:** The gear pump cannot handle the low suction pressure / NPSHa or is cavitating.
- **Solution:** Three-screw pumps have an excellent suction lift performance.
- **Background:** The small peripheral diameters of the rotors and low axial velocity of the fluid provide excellent suction lift performance compared to other pump designs providing similar output flows. This gives the three-screw pump an inherent advantage in negative suction pressure applications allowing the pumping of higher viscosity fluids at much higher speeds than vane or external gear style pumps.

Noise

- **Problem:** The noise level matters. A gear pump is too noisy.
- **Solution:** three-Screw pumps have 15-20 db lower noise emission compared to a gear pump.
- **Background:** As mentioned in previous point, the low pulsation significantly reduces the noise emission by 15-20 dB compared to a gear pump. The noise of metal-to-metal contact is significantly higher than smooth rolling of screws. The noise emission of a three-screw pump is therefore usually significantly lower than that of the drive motor.

Non-newtonian and shear sensitive fluids

- **Problem:** The fluid is non-Newtonian and/or shear sensitive.
- **Solution:** three-screw pumps have excellent capabilities in handling non-Newtonian, shear sensitive fluids.
- **Background:** Shear can change the viscosity of non-newtonian fluids extremely. Depending on the fluid, this can be acceptable or even destroy it. While gear pumps need to be adopted with extra large clearances and low speed operation to handle these fluids, a three-screw due to it's small peripheral diameters of the rotors and low fluid axial velocities, naturally handles the fluid very gentle. Shear only appears in the small clearances, the area of slip flow.

Allweiler SNA

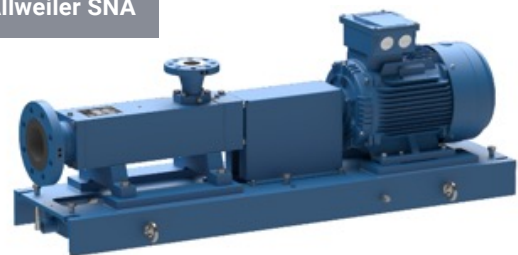

Allweiler EMTEC-C



Allweiler AFI

CIRCOR Confidential & Proprietary

3D + storytelling + Interactivity

GOVIE: THE VIRTUAL SALES TOOL OF THE FUTURE

Innovative products deserve innovative presentations

We all know how difficult and expensive 3D printed products are, and with the new normality of the post-pandemic, online meetings becoming more and more common, we need new tools to get closer to our customers and show them how our products can solve their pain points.

In this new digital era, at CIRCOR we have adapted quickly to offer powerful solutions that make it easier to do business with us, communicate our value proposition and differentiate ourselves from our competitors, improving the positive customer experience.

Today we are proud to introduce our "Govies", a new digital technology that allows the configuration of products in three dimensions, reinventing the presentation of products to the customer able to:

- Share links or QR codes with our customers as product presentation.
- Creating personalized storytelling.
- Promote new products.
- Create animations for ad-hoc presentations that focus on customer needs.

We encourage you to share your needs and suggestions with us to help us create new Govies to help you communicate with your customers.



ALLWEILER SNA
(short version)



ALLWEILER AEB-DE
(short version)





NEW DIGITAL SHOWROOM

CIRCOR opens up a new world of possibilities with its new virtual showroom.

The world has changed and it is essential to adapt to the new situation. In this new context we want to remain connected with our clients and now it is possible through a new virtual world.

In our showroom, the user will learn about the history of CIRCOR, its brands, will delve into its technologies, its pumps, all in a virtual and interactive way, mixing image and video to improve the experience.



CIRCOR Confidential & Proprietary



NEW WEB PAGE

New user experience & look and feel

CIRCOR's digital transformation strategy has the goal of establishing a clear market and customer orientation. It was obvious that the first thing we had to improve was our web presence. We want to accomplish:

- Ease of doing business.
- Increase the traffic to the website and time per visit.
- Generate leads from visitors to our site and channel the leads to the sales organization.
- New design adapted to people with disabilities.

How are we going to achieve this?

- New design focused on product brands, as the product brands are the ones that are recognized by the consumer.
- Improving the user's digital experience:
 - easy navigation: quick finder for products; quick finder sales leads
 - products, markets, brands and fluids are connected

- content and navigation according to the different users (I want a quick search or I want to be informed about the solutions you can offer me)
- virtual experiences of applications or marketplaces showing the products and with request forms to generate leads
- Shortening response time
 - Contact form directly addressed to our channel partners to shorten customer response time.
 - Chatbot
 - Aftermarket landing page
 - CIRCORSmart in web version
- Login area for our channel partners
 - A common place to access to all information

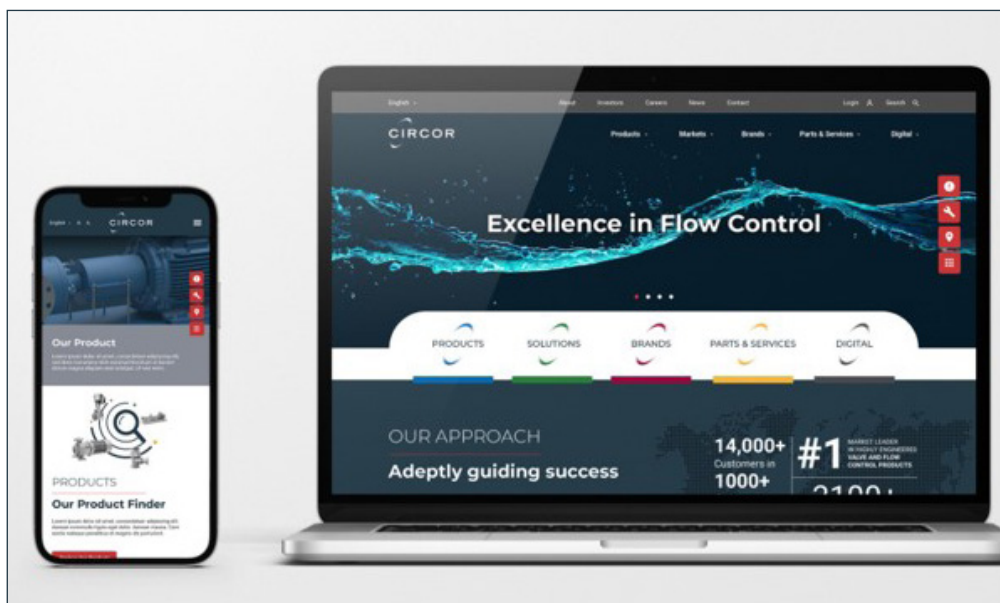

CIRCOR Confidential & Proprietary



ALLWEILER®
IMO®
HOUTTUIN®
TUSHACO®
WARREN®
ZENITH®